

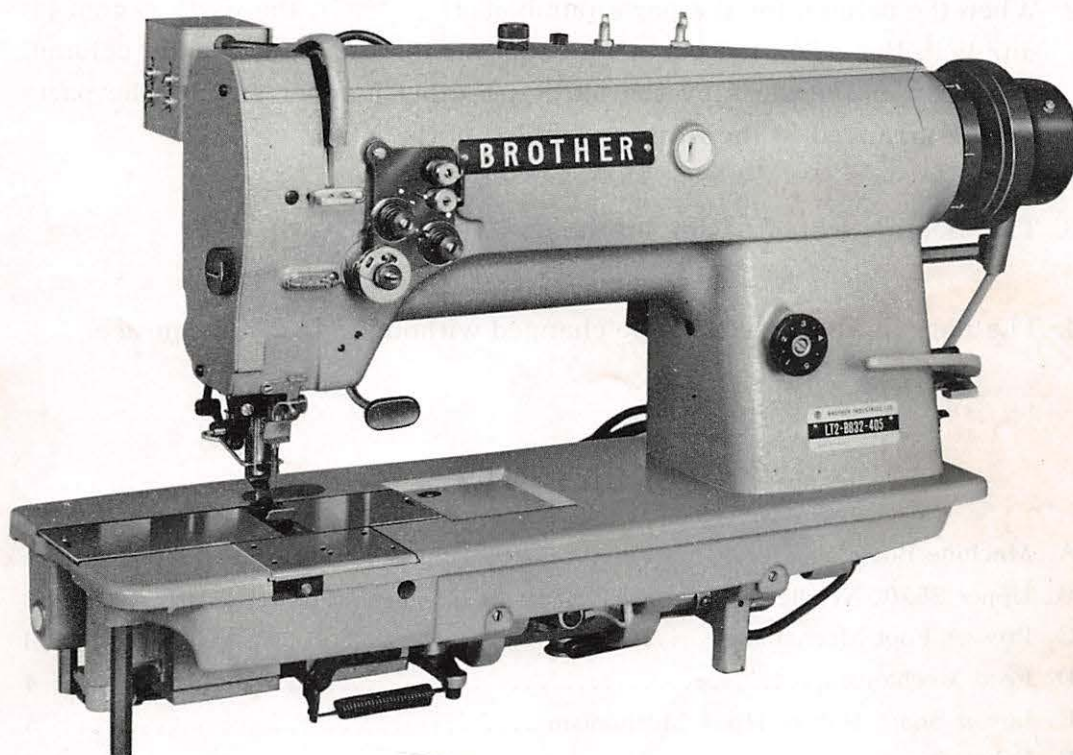

PARTS BOOK
FOR
BROTHER LT2-B832-400



**Twin Needle Needle Feed Lock Stitcher
with Automatic Thread Trimmer**

BROTHER INDUSTRIES, LTD.
NAGOYA, JAPAN

How to use the parts book

1. When the column for the parts number or the parts assembly number is , please refer to the different parts list on the page 14.
2. When the column for the parts number is , the parts cannot be supplied. But when the parts assembly number is shown in the column, please order the parts by the parts assembly number so that the parts can be arranged in the form assembled parts.
3. This book is edited basing on the data as of the April, 1977.
4. The parts in this book may be changed without any advance notice.

CONTENTS

A. Machine Body	1
B. Upper Shaft, Needle Bar and Rock Shaft Mechanism	2
C. Presser Foot Mechanism	3
D. Feed Mechanism	4
E. Lower Shaft, Rotary Hook Mechanism	5
F. Lubrication	6
G. Reverse, Tension Release Mechanism	7
H. Thread Wiper, Reverse Switch Mechanism	8
J. Thread Trimmer Mechanism	9
K. Synchronizer Mechanism	10
N. For 45402 45403 (Heavy) Exclusive Parts	11
S. For 43402 43403 (Thin, Medium) Exclusive Parts	12
Z. Accessories	13
DIFFERENT PARTS LIST	14
INDEX	15

A. Machine Body

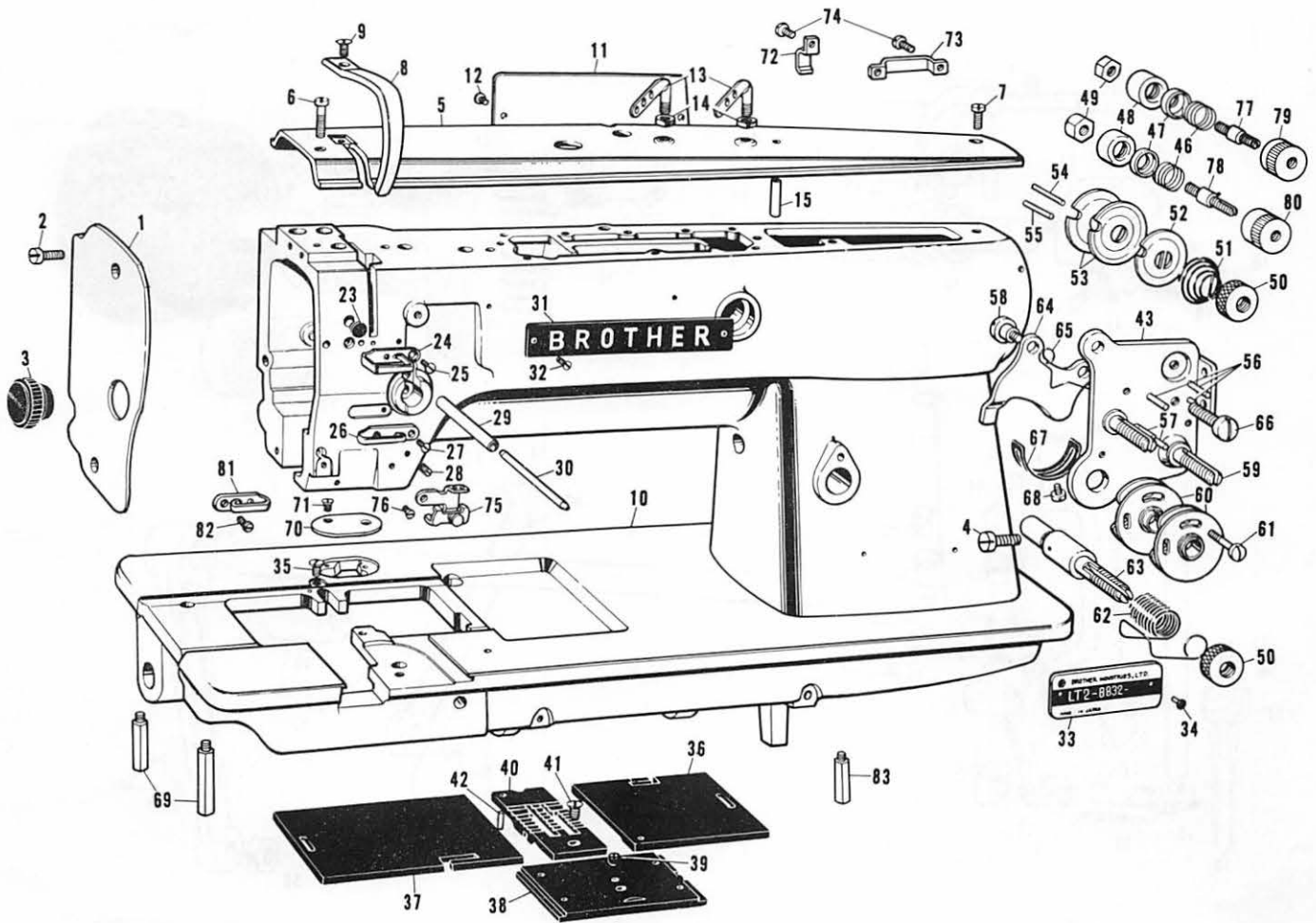

Ref. No.	Name of Parts	Q'ty	Parts No.	Assembly No.	Ref. No.	Name of Parts	Q'ty	Parts No.	Assembly No.
A-1	Face Plate	1	148507-0-01		A-50	Tension Control Nut	3	108265-0-01	Upper Tension Control Assembly
A-2	Screw	2	009670-8-12		A-51	Tension Spring	2		
A-3	Face Plate Cap	1	112782-0-01		A-52	Tension Disc Washer	2	148669-0-01	
A-4	Screw	1	100064-0-02		A-53	Tension Disc	4	108263-0-01	
A-5	Arm Top Cover	1	112560-0-01		A-54	Tension Release Pin	1	148671-0-01	
A-6	Screw	1	009681-6-13		A-55	Tension Release Pin	1	148670-0-01	
A-7	Screw	1	009681-0-14		A-56	Pin	3		
A-8	Thread Take-up Cover	1	112561-0-01		A-57	Pin	2		
A-9	Screw	1	107231-0-01		A-58	Screw	2	112712-0-01	
A-10	Arm Bed	1			A-59	Tension Stud	2		
A-11	Rear Cover	1	112566-0-01		A-60	Spring Guide	2	108254-0-01	
A-12	Screw	2	009670-6-14		A-61	Screw	1	144682-0-01	
A-13	Top Cover Thread Guide	2	140527-0-01		A-62	Thread Take-up Spring	1	144681-0-01	
A-14	Nut	2	021760-3-04		A-63	Tension Stud	1	144680-0-01	
A-15	Oil Pipe	1	112696-0-00		A-64	Tension Release Plate	1	144683-0-01	
A-23	Oil Cap	1	104450-0-01		A-65	Tension Release Spring	1	118320-0-01	
A-24	Arm Thread Guide Upper	1	108266-0-01		A-46	Thread Guide Spring	2	148668-0-01	
A-25	Screw	1	108960-0-04		A-47	Thread Disc	2	148667-0-01	
A-26	Arm Thread Guide Center	1	112658-0-01		A-48	Thread Guide Bracket	2	148666-0-01	
A-27	Screw	1	108960-0-04		A-77	Thread Guide Screw A	1	148662-0-01	
A-28	Screw	2	013680-6-12		A-78	Thread Guide Screw B	1	148663-0-01	
A-29	Pipe	1	148604-0-00		A-79	Tension Control Nut A	1	148664-0-01	
A-30	Tension Release Bar	1	148610-0-01		A-80	Tension Control Nut B	1	148665-0-01	
A-31	Name Plate	1			A-66	Screw	1	009681-0-14	
A-32	Screw	2			A-67	Stopper	1	112709-0-01	
A-33	Model Plate	1			A-68	Screw	1	009670-6-13	
A-34	Pin	2			A-69	Bed Leg	2	148611-0-01	
A-35	Screw	1	112751-0-02		A-70	Cover	1	148614-0-01	
A-36	Slide Plate, Right	1	112607-0-01		A-71	Screw	2	141542-0-02	
A-37	Slide Plate, Left	1	112606-0-01		A-72	Cord Holder	2	142268-0-01	
A-38	Slide Plate, Front	1	148599-0-01		A-73	Cord Holder	1	148818-0-01	
A-39	Screw	1	116010-0-01		A-74	Screw	4	009670-6-12	
A-40	Needle Plate	1			A-75	Thread Guide Assembly	1		
A-41	Screw	1	100032-0-03		A-76	Screw	1		
A-42	Pin	1	113386-0-00		A-81	Arm Thread Guide Lower	1		
A-43	Upper Thread Tension Plate	2			A-82	Screw	1		
A-49	Nut	2	021670-1-60		A-83	Bed Leg S	1	149179-0-01	

B. Upper Shaft, Needle Bar and Rock Shaft Mechanism

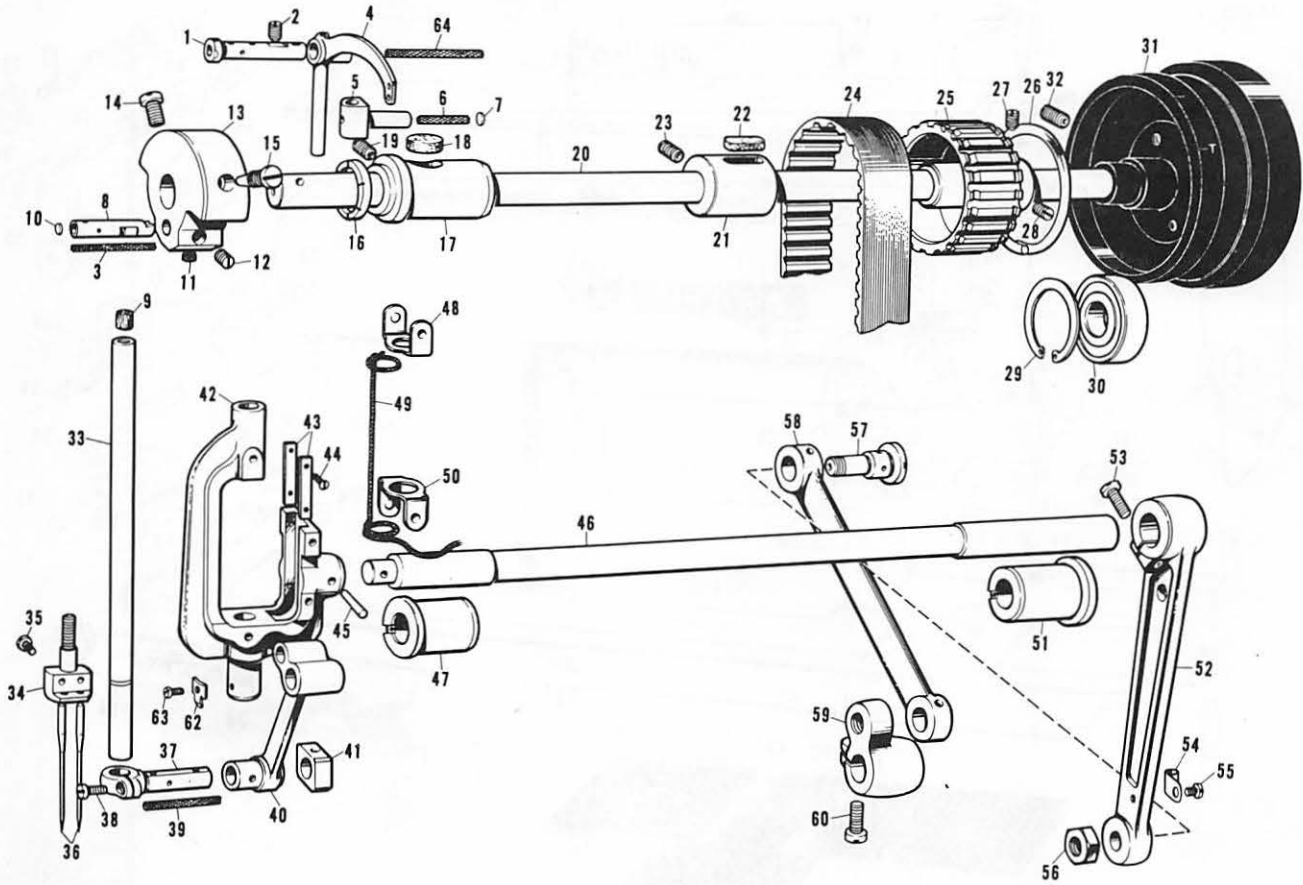

Ref. No.	Name of Parts	Q'ty	Parts No	Assembly No.	Ref. No.	Name of Parts	Q'ty	Parts No.	Assembly No.
B- 1	Stud	1	112579-0-01		B-34	Needle Clamp	1	112600-0-01	
B- 2	Screw	1	013761-0-10		B-35	Screw	2	116323-0-01	
B- 3	Wick	1	112735-0-00		B-36	Needle DP×5	2		
B- 4	Thread Take-up Lever	1	112578-0-01		B-39	Wick	1	112728-0-01	
B- 5	Thread Take-up Lever Slide Block	1	118171-0-01		B-37	Needle Bar Clamp	1	112592-0-01	
B- 6	Wick	1	114693-0-01		B-38	Screw	1	009670-8-12	
B- 7	Pusher	1	113024-0-00		B-33	Needle Bar	1	148597-0-01	
B- 8	Needle Bar Crank	1	112577-0-01		B-40	Needle Bar Clank Rod	1	112593-0-01	
B- 9	Needle Bar Cap	1	148394-0-00		B-41	Needle Bar Guide Slide Block	1	112721-0-01	
B-10	Pusher	1	113014-0-00		B-42	Needle Bar Support	1	148596-0-00	
B-11	Screw	1	101706-0-01		B-43	Needle Bar Guide Plate	2	112590-0-01	
B-12	Screw	1	013770-7-10		B-44	Screw	4	102731-0-01	
B-13	Counter Weight	1	112574-0-00		B-45	Pin	1	107030-0-01	
B-14	Screw	1	146141-0-01		B-46	Needle Bar Rock Shaft	1	112588-0-01	
B-15	Screw	1	100250-0-01		B-47	Needle Bar Rock Shaft Bushing Left	1	112594-0-01	
B-16	Thrust Ring	1	112576-0-01		B-48	Wick Presser (Upper)	1	112719-0-01	
B-17	Upper Shaft Bushing Left	1	112573-0-01		B-49	Wick	1	116699-0-00	
B-18	Felt	1	112734-0-01		B-50	Wick Presser (Lower)	1	112720-0-01	
B-19	Screw	1	013761-4-10		B-51	Needle Bar Rock Shaft Bushing Right	1	112764-0-01	
B-20	Upper Shaft	1	112572-0-01		B-52	Needle Bar Connecting Rod	1	112595-0-00	
B-21	Upper Shaft Bushing Center	1	114680-0-01		B-53	Screw	1	105351-0-02	
B-22	Felt	1	100248-0-01		B-54	Wick Supporter	1	112739-0-01	
B-23	Screw	1	013761-4-10		B-55	Screw	1	009670-5-12	
B-24	Timming Belt	1	112586-0-01		B-56	Nut	2	101268-0-03	
B-25	Timming Belt Wheel Upper	1		Timming Belt Wheel Upper Assembly 180157-0-01	B-57	Connecting Link Stud	2	112597-0-01	
B-26	Side Ring	2			B-58	Needle Bar Rock Link	1	112596-0-01	
B-27	Screw	1	015771-2-12		B-59	Needle Bar Rock Crank	1	112598-0-01	
B-28	Screw	1	013771-2-12		B-60	Screw	1	009781-8-12	
B-29	Stop Ring	1	112760-0-01		B-62	Needle	1	148598-0-01	
B-30	Ball Bearing	1	072620-4-60		B-63	Screw	1	105288-0-01	
B-31	Pulley	1	148617-0-01		B-64	Wick	1	112735-0-01	
B-32	Screw	2	013761-4-10						

Needle Bar Rock Shaft Assembly 148595-0-01

From the library of: Diamond Needle Corp.

C. Presser Foot Mechanism

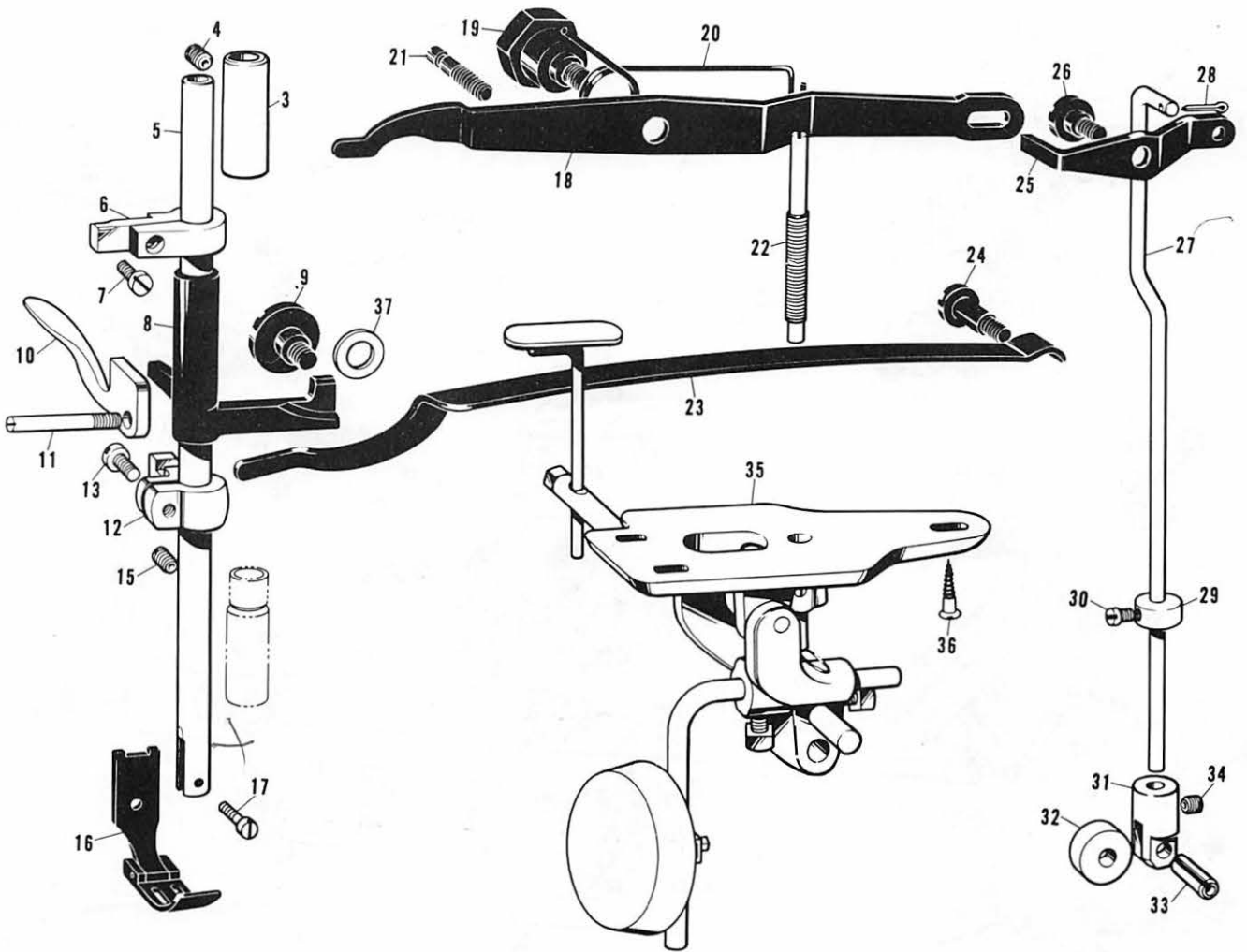

Ref. No.	Name of Parts	Q'ty	Parts No.	Assembly No.	Ref. No.	Name of Parts	Q'ty	Parts No.	Assembly No.
C-3	Presser Bar Bushing Upper	1	112615-0-01		C-20	Spring	1	112629-0-01	
C-4	Screw	1	100260-0-01		C-21	Stopper	1	112630-0-01	
C-5	Presser Bar	1	112614-0-01		C-22	Presser Adjusting Screw	1	112624-0-01	
C-6	Presser Bar Guide	1		Presser Bar Guide 148835-0-01	C-23	Presser Plate Spring	1	118170-0-01	
C-7	Screw	1	009680-7-13		C-24	Screw	1	112623-0-01	
C-8	Presser Bar Lifter	1	148483-0-01		C-25	Knee Lifter Connecting Lever	1	112627-0-01	
C-9	Presser Bar Lifter Guide	1	112631-0-01		C-26	Screw	1	112628-0-01	
C-10	Presser Foot Lifter	1	112618-0-01		C-27	Knee Lifter Connecting Rod	1	148484-0-01	
C-11	Presser Foot Lifter Shaft	1	112619-0-01		C-28	Pin	1	114909-0-00	
C-12	Presser Bar Bracket	1	112616-0-01		C-29	Collar	1	112634-0-02	
C-13	Screw	1	009670-8-12		C-30	Screw	1	104908-0-04	
C-15	Screw	1	013760-8-10		C-31	Roller Bracket	1		Knee Lifter Roller Bracket 116276-0-01
C-16	Presser Foot	1			C-32	Roller	1	112636-0-01	
C-17	Screw	1	113050-0-01		C-33	Pin	1	047501-2-42	
C-18	Knee Lifter Lever	1	148486-0-01		C-34	Screw	1	013689-4-12	
C-19	Screw	1	112626-0-01		C-35	Knee Lifter Assembly	1	148674-0-01	
					C-36	Screw	3	106030-0-01	
					C-37	Collar	1	148605-0-01	

D. Feed Mechanism

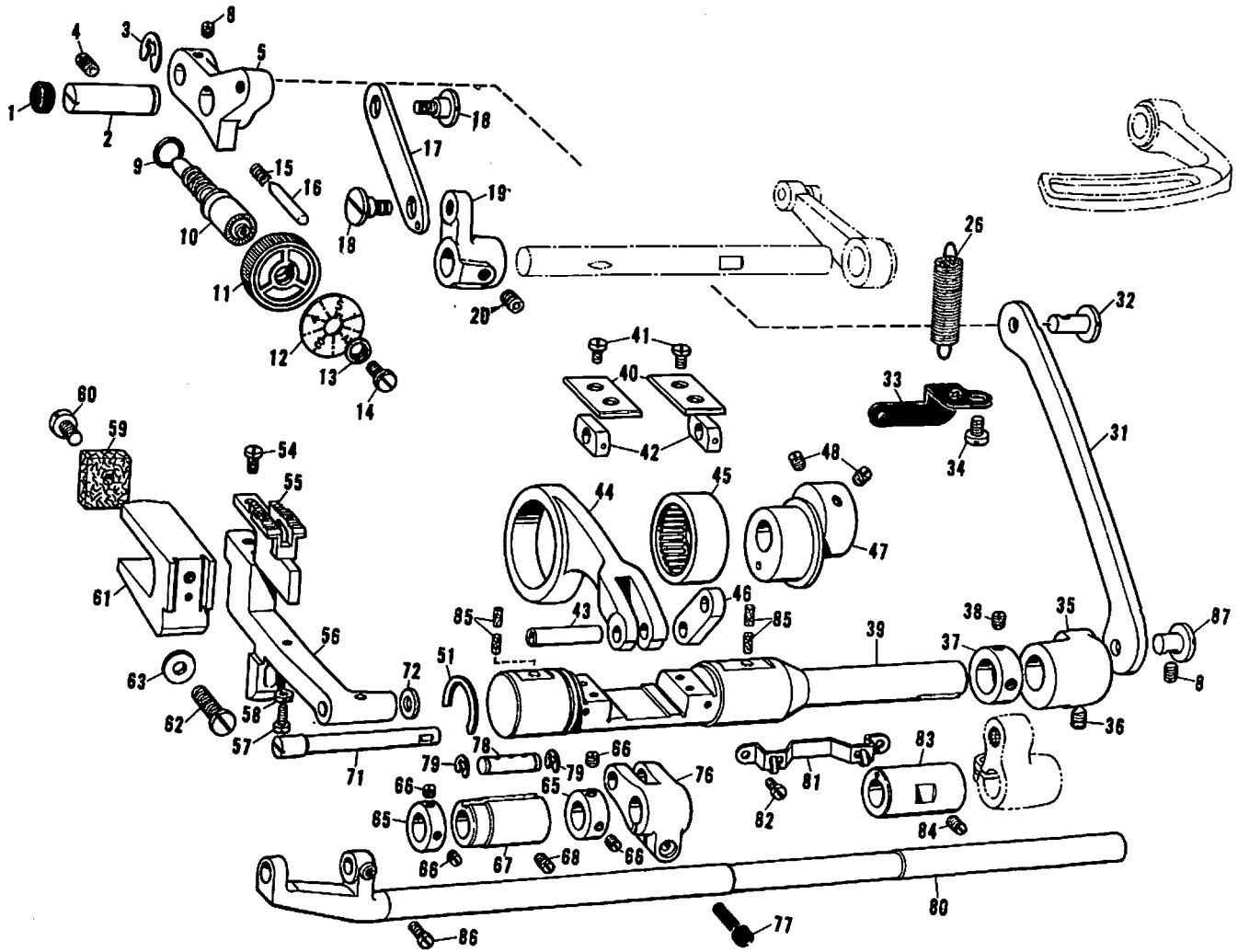

Ref. No.	Name of Parts	Q'ty	Parts No.	Assembly No.	Ref. No.	Name of Parts	Q'ty	Parts No.	Assembly No.
D-1	Oil Cap	1	143766-0-01		D-45	Needle Bearing	1	118954-0-00	Level Feed Connecting Rod Assembly 148801-0-01
D-2	Feed Regulator Stud	1	148488-0-01		D-46	Level Feed Connecting Link	1	143613-0-01	
D-3	Stop Ring	1	048070-3-42		D-47	Eccentric Wheel	1		Eccentric Wheel 148802-0-01
D-4	Screw	1	013761-0-10		D-48	Screw	2	013761-0-10	
D-5	Feed Regulator	1	148489-0-01		D-51	Stop Ring	1	143597-0-01	
D-8	Screw	2	013680-6-10		D-54	Screw	2	116283-0-01	
D-9	Packing	1	108549-0-01		D-55	Feed Dog	1		
D-10	Length Control Screw	1	143598-0-01		D-56	Feed Bar	1	148490-0-01	
D-11	Length Control	1	142483-0-01		D-57	Screw	1	107278-0-02	
D-12	Length Control Plate	1			D-58	Nut	1	021660-1-03	
D-13	Washer	1	142746-0-01		D-59	Felt	1	112759-0-01	
D-14	Screw	1	142747-0-01		D-60	Screw	1	100242-0-03	
D-15	Spring	1	100328-0-01		D-61	Feed Bar Fork	1	112656-0-01	
D-16	Pin	1	145502-0-01		D-62	Screw	1	009761-4-12	
D-17	Connecting Plate	1	118746-0-01		D-63	Washer	1	025060-1-32	
D-18	Screw	2	112072-0-01		D-65	Collar	2	113074-0-01	
D-19	Feed Regulator Bracket	1	118747-0-01		D-66	Screw	4	101706-0-01	
D-20	Screw	1	118853-0-01		D-67	Feed Dog Rock Shaft Bushing Left	1	148494-0-01	
D-26	Spring	1	148726-0-01		D-68	Screw	1	013761-4-10	
D-31	Feed Regulator Connecting Link	1	148487-0-01		D-71	Feed Bar Shaft	1	148491-0-01	
D-32	Link Pin	1	118713-0-01		D-72	Thrust Ring	2	143591-0-01	
D-33	Spring Hook Plate	1	143610-0-01		D-76	Lever Feed Arm	1	148495-0-01	
D-34	Screw	1	009710-8-12		D-77	Screw	1	009781-8-12	
D-35	Feed Regulator Arm	1			D-78	Stud	1	143616-0-01	
D-36	Screw	1	118853-0-01		D-79	Stop Ring	2	048060-3-42	
D-37	Collar	1		Collar Assembly 180321-0-01	D-80	Feed Rock Shaft	1	148492-0-01	
D-38	Screw	2	101706-0-01		D-81	Wick Support	1	143673-0-01	
D-39	Feed Regulator Shaft	1		Feed Regulator Shaft Assembly 148771-0-01	D-82	Screw	2	009660-4-12	
D-40	Slide Block Guide Plate	2	143594-0-01		D-83	Feed Dog Rock Shaft Bushing Right	1	148493-0-01	
D-41	Screw	4	009681-0-12		D-84	Screw	1	013761-4-10	
D-42	Feed Regulator Slide Block	2		Slide Block 145328-0-01	D-85	Felt	4	148743-0-01	
D-43	Feed Regulator Slide Block Shaft	1			D-86	Screw	1	104908-0-04	
D-44	Lever Feed Connecting Rod	1	148496-0-00		D-87	Pin	1	148501-0-01	

E. Lower Shaft, Rotary Hook Mechanism

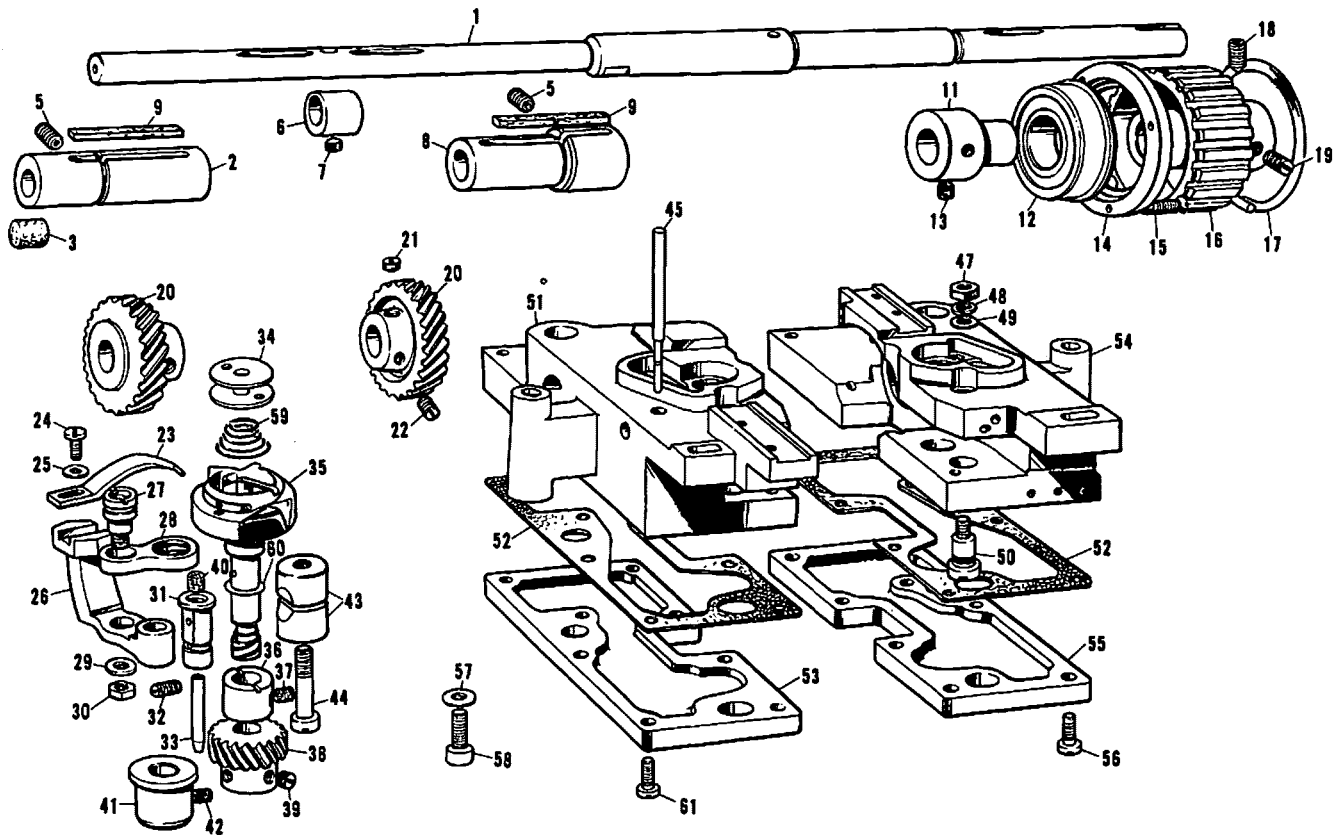

Ref. No.	Name of Parts	Q'ty	Parts No.	Assembly No.	Ref. No.	Name of Parts	Q'ty	Parts No.	Assembly No.
E-1	Lower Shaft	1	148505-0-01		E-30	Nut	2	021710-2-12	
E-2	Rotary Hook Base Bushing Left	1	148503-0-00		E-31	Opener Crank Stud	2	112695-0-01	
E-3	Felt	1	115249-0-01		E-32	Screw	2	011711-4-12	
E-5	Screw	2	013760-8-10		E-33	Pipe	1	112696-0-00	
E-6	Vertical Feed Eccentric Wheel	1		Vertical Feed Eccentric Assembly	E-34	Bobbin	2	148603-0-01	
E-7	Screw	1	112684-0-01		E-35	Rotary Hook	2	148618-0-01	
E-8	Rotary Hook Base Bushing Right	1	148502-0-00		E-36	Rotary Hook Shaft Bushing Upper	2	112690-0-01	
E-9	Felt	2	113362-0-01		E-37	Screw	2	107794-0-01	
E-11	Bushing	1	112667-0-01	Bushing	E-39	Screw	6	101706-0-01	
E-12	Ball Bearing	1	112666-0-00	112698-0-01	E-40	Felt	2	107155-0-01	
E-13	Screw	2	013780-7-10		E-41	Rotary Hook Shaft Bushing Lower	2	112687-0-01	
E-14	Bearing Presser	1	112668-0-01		E-42	Screw	2	107794-0-01	
E-15	Screw	3	005671-2-12		E-43	Pinch Sleeve	2	112699-0-01	
E-16	Timming Belt Wheel Lower	1		Timming Belt Pulley Lower Assembly	E-44	Screw	2	112700-0-01	
E-17	Side Ring	1		148803-0-01	E-45	Oil Gauge	2	148728-0-01	
E-18	Screw	1	148821-0-01		E-47	Nut	2	105234-0-01	
E-19	Screw	2	013771-2-12		E-48	Washer	2	028680-2-43	
E-20	Spiral Gear	2		Spiral Gear Assembly	E-49	Washer	2	100645-0-03	
E-38	Pinion	2		180949-0-01	E-50	Oil Adjusting Screw	2	112756-0-01	
E-21	Screw	2	112684-0-01		E-51	Rotary Hook Base Left	1	148481-0-01	
E-22	Screw	4	013770-7-10		E-52	Packing	2	112755-0-01	
E-23	Bobbin Case Opener	2	112697-0-01		E-53	Oil Reservoir Left	1	112686-0-01	
E-24	Screw	2	009670-8-12		E-54	Rotary Hook Base Right	1	148480-0-01	
E-25	Washer	2	105161-0-02		E-55	Oil Reservoir Right	1	112702-0-01	
E-26	Opener Crank	2	112694-0-01		E-56	Screw	8	100320-0-02	
E-27	Opener Link Stud	2	148005-0-01		E-57	Washer	2	025770-2-32	
E-28	Opener Link	2	112692-0-01		E-58	Bolt	2	149569-0-01	
E-29	Washer	2	025710-2-32		E-59	Spring	2		
					E-60	Spacer 0.6	2	148727-0-01	
					E-60	Spacer 0.4	4	148819-0-01	
					E-61	Screw	8	100320-0-02	

F. Lubrication

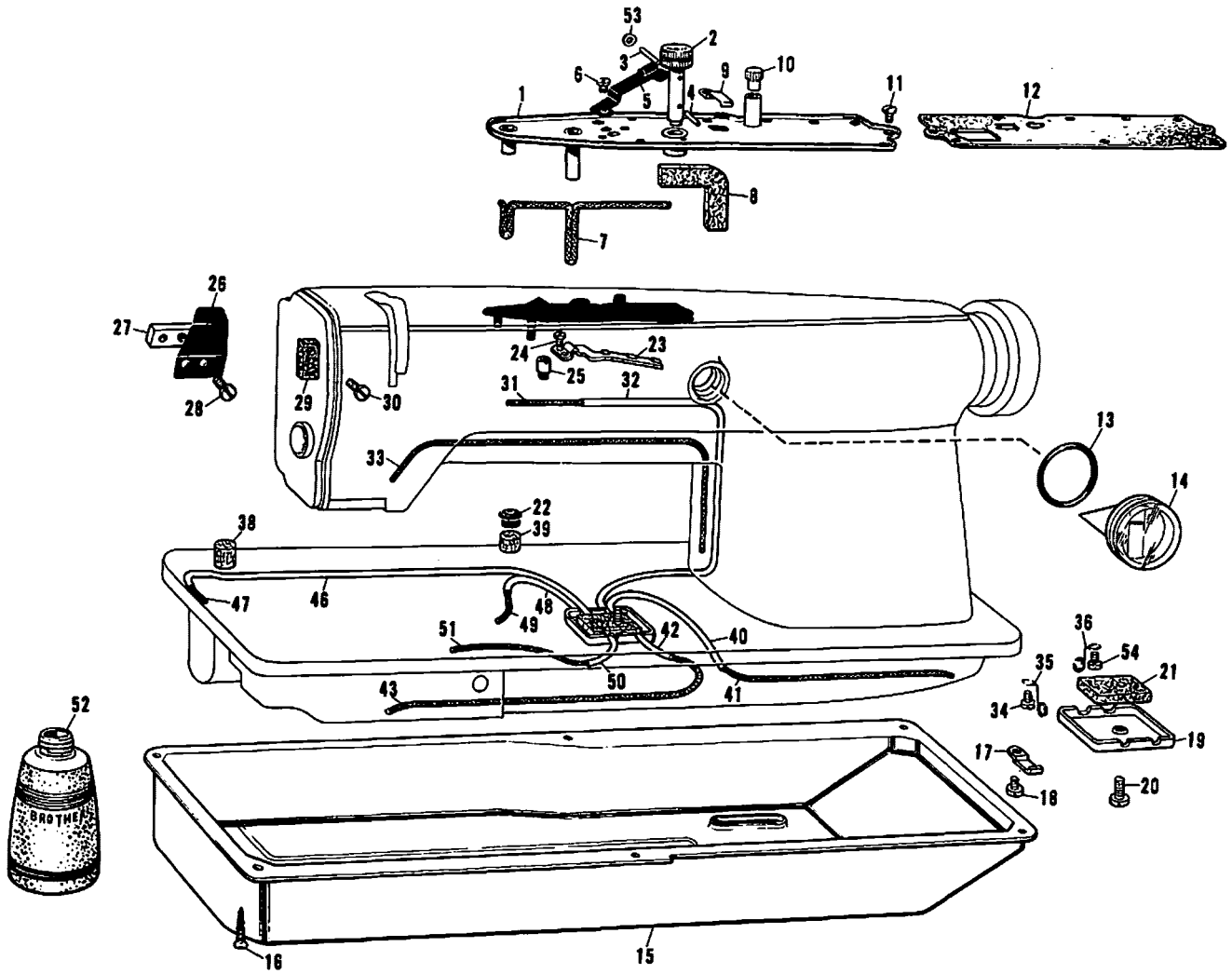

Ref. No.	Name of Parts	Q'ty	Parts No.	Assembly No.	Ref. No.	Name of Parts	Q'ty	Parts No.	Assembly No.
F-1	Oil Receiver Plate	1		Oil Receiver Plate Assembly 112762-0-01	F-27	Oil Stopper Plate Presser	1	112717-0-01	
F-2	Oil Adjusting Knob	1			F-28	Screw	1	009710-8-12	
F-3	Pin	1			F-29	Felt	1	148762-0-01	
F-4	Pin	1			F-30	Screw	1	001670-6-12	
F-5	Wick Supporter	1	112730-0-01		F-31	Wick	1	148731-0-00	
F-6	Screw	1	009679-3-12		F-32	Oil Tube	1	148730-0-01	
F-7	Wick	1	112725-0-01		F-33	Wick	1	112736-0-00	
F-8	Felt	1	112724-0-01		F-34	Screw	1	009670-5-12	
F-9	Felt Presser	1	114297-0-01		F-35	Wick Holder	1	112745-0-01	
F-10	Oil Cap	1	113526-0-01		F-36	Wick Holder	3	112743-0-01	
F-11	Screw	10	009670-6-13		F-38	Felt	1	112754-0-01	
F-12	Packing	1	112723-0-01		F-39	Felt	1	112753-0-01	
F-13	Packing	1	081016-0-70	F-40	Oil Tube	1	148733-0-01		
F-14	Oil Gauge Window	1	116558-0-01	F-41	Wick	1	148734-0-00		
F-15	Oil Pan	1	143972-0-01	F-42	Oil Tube	1	148737-0-01		
F-16	Screw	6	031311-3-02	F-43	Wick	1	148738-0-00		
F-17	Oil Tube Holder	2	114297-0-01	F-46	Oil Tube	1	148741-0-01		
F-18	Screw	2	009670-5-12	F-47	Wick	1	148742-0-00		
F-19	Bed Oil Tube Holder	1	148729-0-01	F-48	Oil Tube	1	148733-0-01		
F-20	Screw	1	009711-0-12	F-49	Wick	1	148740-0-00		
F-21	Felt	1	148732-0-01	F-50	Oil Tube	1	148735-0-01		
F-22	Oil Cap	1	112758-0-01	F-51	Wick	1	148736-0-00		
F-23	Wick Support	1	143657-0-01	F-52	Oiler	1	114486-0-01		
F-24	Screw	2	106640-0-01	F-53	Washer	1	503093-0-01		
F-25	Oil Tube Guide	1	113524-0-01	F-54	Screw	3	009670-5-12		
F-26	Oil Stopper Plate	1	112716-0-01						

G. Reverses, Tension Release Mechanism

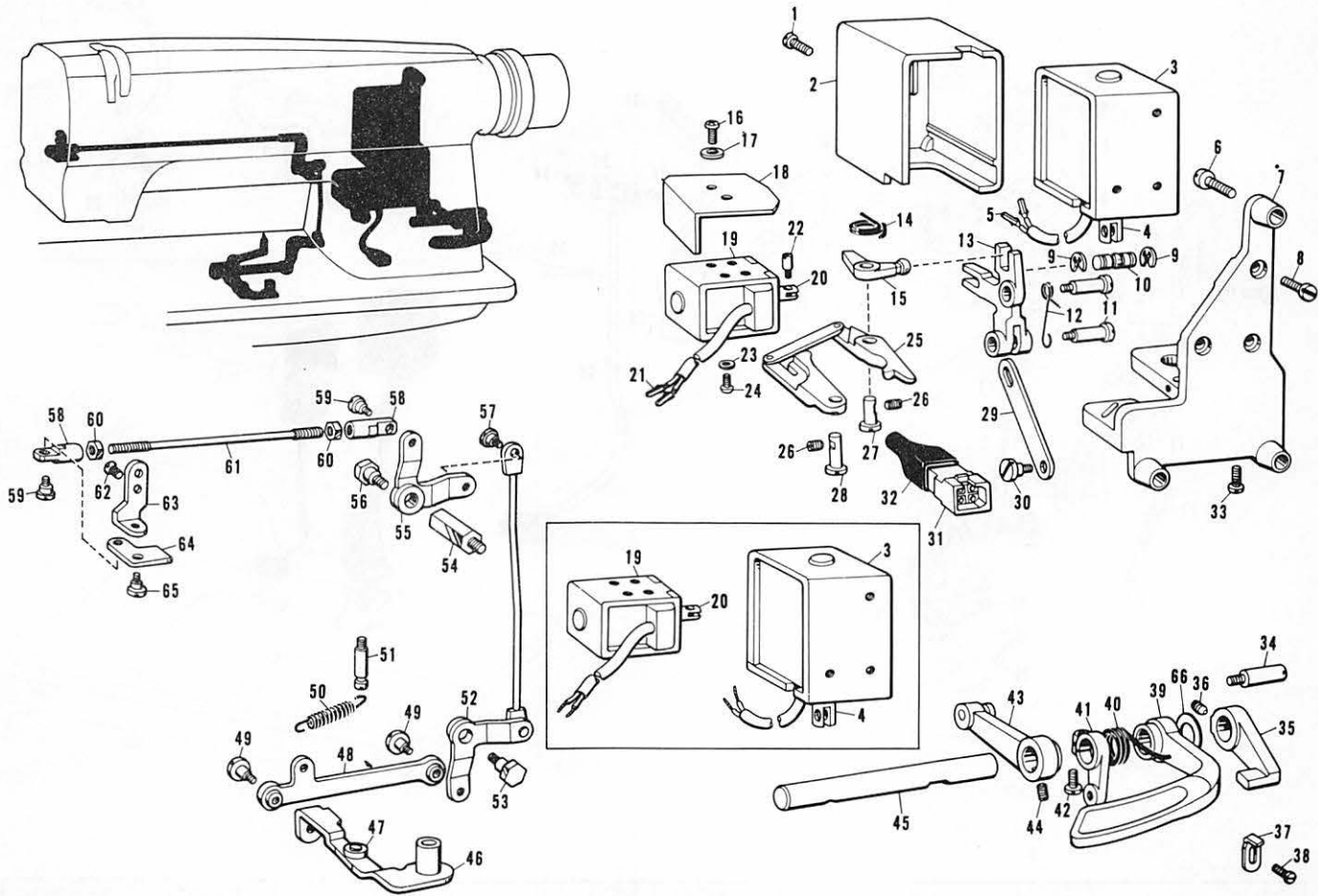

Ref. No.	Name of Parts	Q'ty	Parts No.	Assembly No.	Ref. No.	Name of Parts	Q'ty	Parts No.	Assembly No.
G-1	Screw	1	007500-6-02		G-35	Reverse Lever B	1	148607-0-01	
G-2	Solenoid Cover	1	148560-0-01		G-36	Screw	1	015771-0-12	
G-3	Reverse Solenoid	1		Reverse Solenoid Assembly	G-37	Stopper	1	118865-0-01	
G-4	Plunger	1	148637-0-01		G-38	Screw	1	009680-7-14	
G-5	Terminal Pin				G-39	Reverse Lever	1	148606-0-01	
G-6	Screw	3	009782-5-12		G-40	Spring	1	148608-0-01	
G-7	Reverse Solenoid Bracket	1	148643-0-01		G-41	Reverse Lever Shaft Arm	1	148640-0-01	
G-8	Screw	3	007500-8-02		G-42	Screw	1	009711-4-12	
G-9	Stop Ring	2	048040-3-42		G-43	Feed Regulator Link	1	148638-0-01	
G-10	Pin	1	149174-0-01		G-44	Screw	1	014760-6-22	
G-11	Screw	2	148764-0-01		G-45	Reverse Lever Shaft	1	148609-0-01	
G-12	Spring	1	148652-0-01		G-46	Tension Release Rock Lever	1		Tension Release Rock Lever Assembly 148619-0-01
G-13	Reverse Crank	1	148642-0-01		G-47	Tension Release Roller Stud	1		
G-14	Spring	1	148653-0-01		G-48	Tension Release Connecting Rod Lower	1	148623-0-01	
G-15	Stopper Lever	1	148765-0-01		G-49	Screw	2	123882-0-01	
G-16	Screw	2	002300-5-05		G-50	Spring	1	148654-0-01	
G-17	Washer	2	025030-2-32		G-51	Spring Hook	1	115177-0-01	
G-18	Solenoid Cover	1	148774-0-01		G-52	Tension Release Crank Lower	1	148625-0-01	
G-19	Solenoid	1		Solenoid Assembly	G-53	Screw	1	148628-0-01	
G-20	Plunger	1	148650-0-01		G-54	Stud	1	148629-0-01	
G-21	Terminal Pin				G-55	Tension Release Crank Upper	1	148630-0-01	
G-22	Plunger Pin	1	148651-0-01		G-56	Screw	1	148628-0-01	
G-23	Washer	4	025030-2-33		G-57	Screw	1	110171-0-02	
G-24	Screw	4	002300-6-03		G-58	Joint	2	148632-0-01	
G-25	Stopper	1	148763-0-01		G-59	Screw	2	148768-0-01	
G-26	Screw	2	013680-6-12		G-60	Nut	2	021670-1-02	
G-27	Link Pin	1	118713-0-01		G-61	Tension Release Connecting Rod Upper	1	148631-0-01	
G-28	Pin	1	148767-0-01		G-62	Screw	2	117160-0-01	
G-29	Reverse Link	1	148641-0-01		G-63	Tension Release Plate	1	148634-0-01	
G-30	Screw	1	110171-0-01		G-64	Tension Release Crank	1	148635-0-01	
G-31	Connector	1			G-65	Screw	1	148633-0-01	
G-32	Connector Cap	1			G-66	Washer	1	149554-0-01	
G-33	Screw	1	107419-0-02						
G-34	Screw	1	141748-0-01						

H. Thread Wiper, Reverse Switch Mechanism

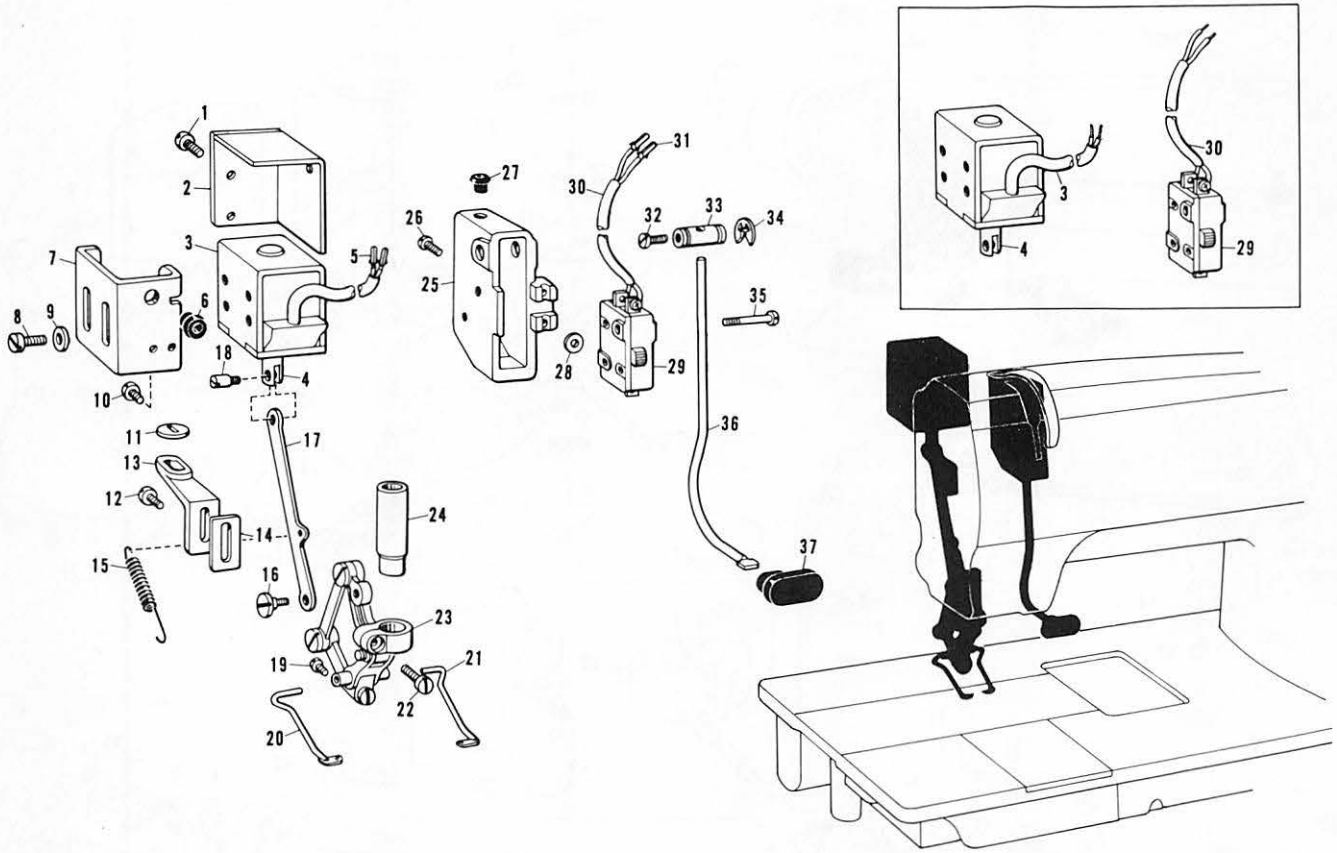

Ref. No.	Name of Parts	Q'ty	Parts No.	Assembly No.	Ref. No.	Name of Parts	Q'ty	Parts No.	Assembly No.
H-1	Screw	3	009679-3-12		H-20	Thread Wiper Left	1	148530-0-01	
H-2	Solenoid Cover	1	148514-0-01		H-21	Thread Wiper Right	1	148529-0-01	
H-3	Solenoid	1		Thread Wiper Solenoid	H-22	Screw	1	009711-4-13	
H-4	Plunger	1	148511-0-01		H-23	Thread Wiper Link	1	148770-0-01	
H-5	Plunger Pin				H-24	Presser Bar Bushing Lower	1	148508-0-01	
H-6	Cord Bushing	1	146080-0-00		H-25	Reverse Switch Case	1	146120-0-01	
H-7	Solenoid Bracket	1	148513-0-01		H-26	Screw	2	009671-0-12	
H-8	Screw	4	007401-0-13		H-27	Cord Bushing	1	146080-0-00	
H-9	Washer	4	025040-2-33		H-28	Washer	2	403616-0-01	
H-10	Screw	2	107407-0-03		H-29	Reverse Switch	1		Switch
H-11	Stopper	1	148518-0-00		H-30	Reverse Switch Cord	1		
H-12	Screw	2	107407-0-03		H-31	Terminal Pin			
H-13	Stopper	1	148516-0-01		H-32	Screw	1	009681-4-14	
H-14	Stopper	1	148517-0-00		H-33	Actuator Pin	1	146125-0-01	
H-15	Spring	1			H-34	Stop Ring	2	048080-3-42	
H-16	Screw	1	148521-0-01		H-35	Screw	2	146124-0-01	
H-17	Solenoid Link	1	148515-0-01		H-36	Actuator Bar	1	148613-0-01	
H-18	Screw	1	148546-0-01		H-37	Actuator	1	146128-0-00	
H-19	Screw	2	149177-0-01						

J. Thread Trimmer Mechanism

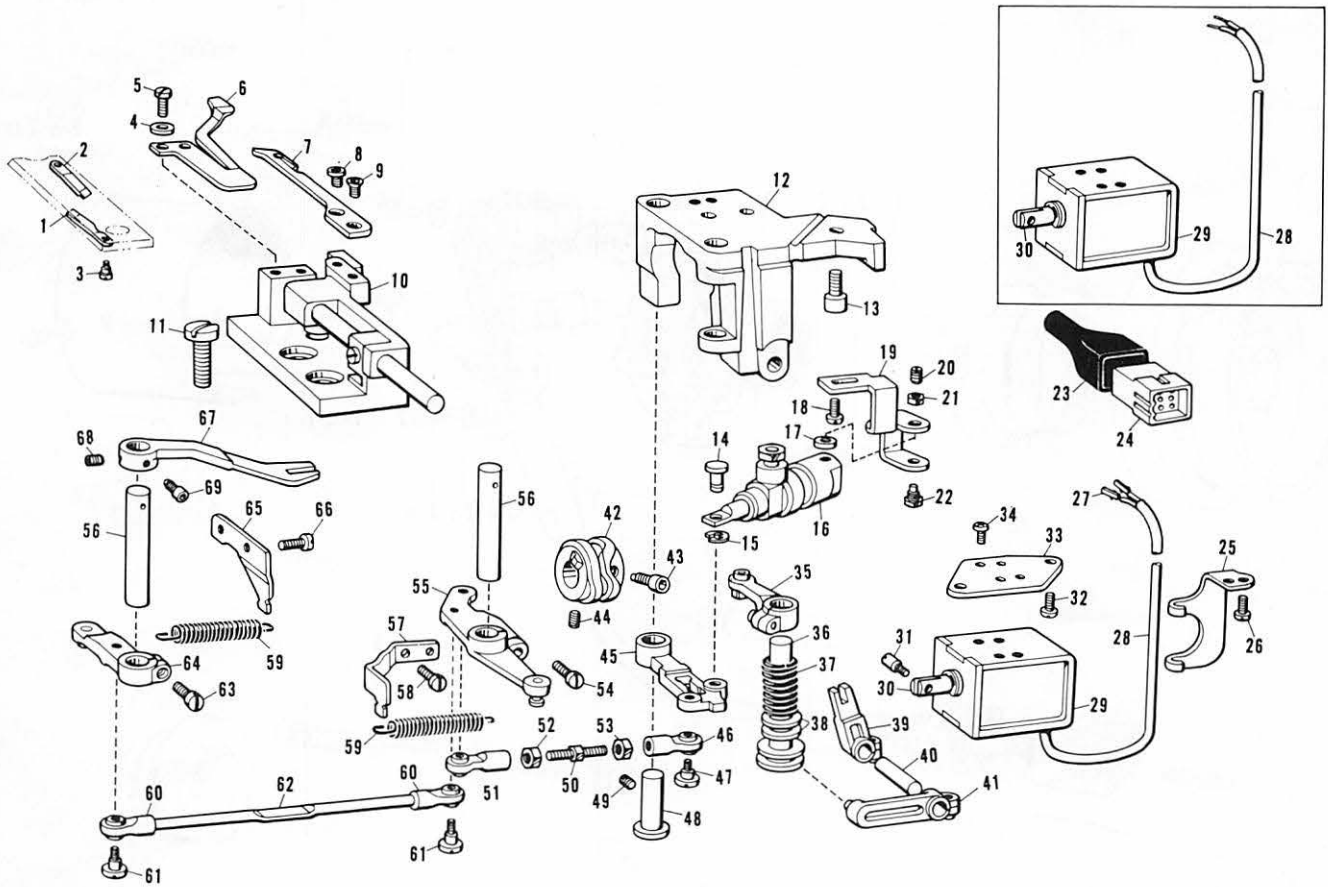

Ref. No.	Name of Parts	Q'ty	Parts No.	Assembly No.	Ref. No.	Name of Parts	Q'ty	Parts No.	Assembly No.
J-1	Fixed Knife Left	1	148538-0-01		J-36	Knife Main Lever Shaft	1	148547-0-01	
J-2	Fixed Knife Right	1	149169-0-01		J-37	Spring	1	148555-0-01	
J-3	Screw	2	148539-0-01		J-38	Rubber	2	148559-0-00	
J-4	Washer	4	025630-1-32		J-39	Knife Driving Lever	1	181713-0-01	
J-5	Screw	4	001630-4-02		J-40	Knife Driving Lever Shaft	1	148557-0-01	
J-6	Thread Presser Plate	2			J-41	Knife Driving Pin Lever	1	181712-0-01	
J-7	Movable Knife	2	148535-0-01		J-42	Knife Driving Cam	1		
J-8	Screw	2	148536-0-01		J-43	Screw	1	148574-0-01	
J-9	Screw	2	148537-0-01		J-44	Screw	1	014770-6-22	
J-10	Movable Knife Base Assembly	2	148531-0-01		J-45	Knife Sub Lever	1	148553-0-01	
J-11	Screw	4	009710-8-12		J-46	Joint Right	1	148587-0-01	
J-12	Movable Knife Base Bracket	1	148482-0-01		J-47	Screw	2	141494-0-01	
J-13	Bolt	3	018061-6-22		J-48	Knife Sub Lever Shaft	1	148554-0-01	
J-14	Damper Stud	1	148567-0-01		J-49	Screw	1	100289-0-03	
J-15	Stop Ring	1	048030-3-42		J-50	Connecting Screw	1	148591-0-01	
J-16	Damper	1	148562-0-01		J-51	Joint Left	1	148589-0-01	
J-17	Bushing	2	143710-0-01		J-52	Nut	1	100022-0-05	
J-18	Screw	2	009781-4-12		J-53	Nut	1	148592-0-01	
J-19	Cylinder Supporter	1	148568-0-01		J-54	Screw	1	009711-4-12	
J-20	Screw	1	011802-0-12		J-55	Knife Rock Lever Right	1	148575-0-01	
J-21	Nut	1	100078-0-13		J-56	Knife Rock Arm Shaft	2	148573-0-01	
J-22	Screw	2	140620-0-01		J-57	Spring Hook Right	1	148579-0-01	
J-23	Connector Cap				J-58	Screw	2	009711-0-12	
J-24	Connector				J-59	Spring	2		
J-25	Cord Supporter	1	148655-0-01		J-60	Joint	2	148584-0-01	
J-26	Screw	2	009710-8-12		J-62	Knife Connecting Bar	1	148586-0-01	
J-27	Terminal Pin				J-61	Screw	2	141494-0-01	
J-28	Solenoid Cord	1		Thread Trimmer Solenoid	J-63	Screw	1	009711-4-12	
J-29	Thread Trimmer Solenoid	1			J-64	Knife Rock Lever Left	1	148577-0-01	
J-30	Plunger	1	148545-0-01		J-65	Spring Hook Left	1	148580-0-01	
J-31	Plunger Pin	1	148546-0-01		J-66	Screw	2	009711-0-12	
J-32	Screw	2	009711-0-12		J-67	Knife Rock Arm	2	148572-0-01	
J-33	Solenoid Support Plate	1	148561-0-01		J-68	Screw	2	014770-6-22	
J-34	Screw	4	002040-8-03		J-69	Screw	2	148574-0-01	
J-35	Knife Main Lever	1	148548-0-01						

K. Synchronizer Mechanism

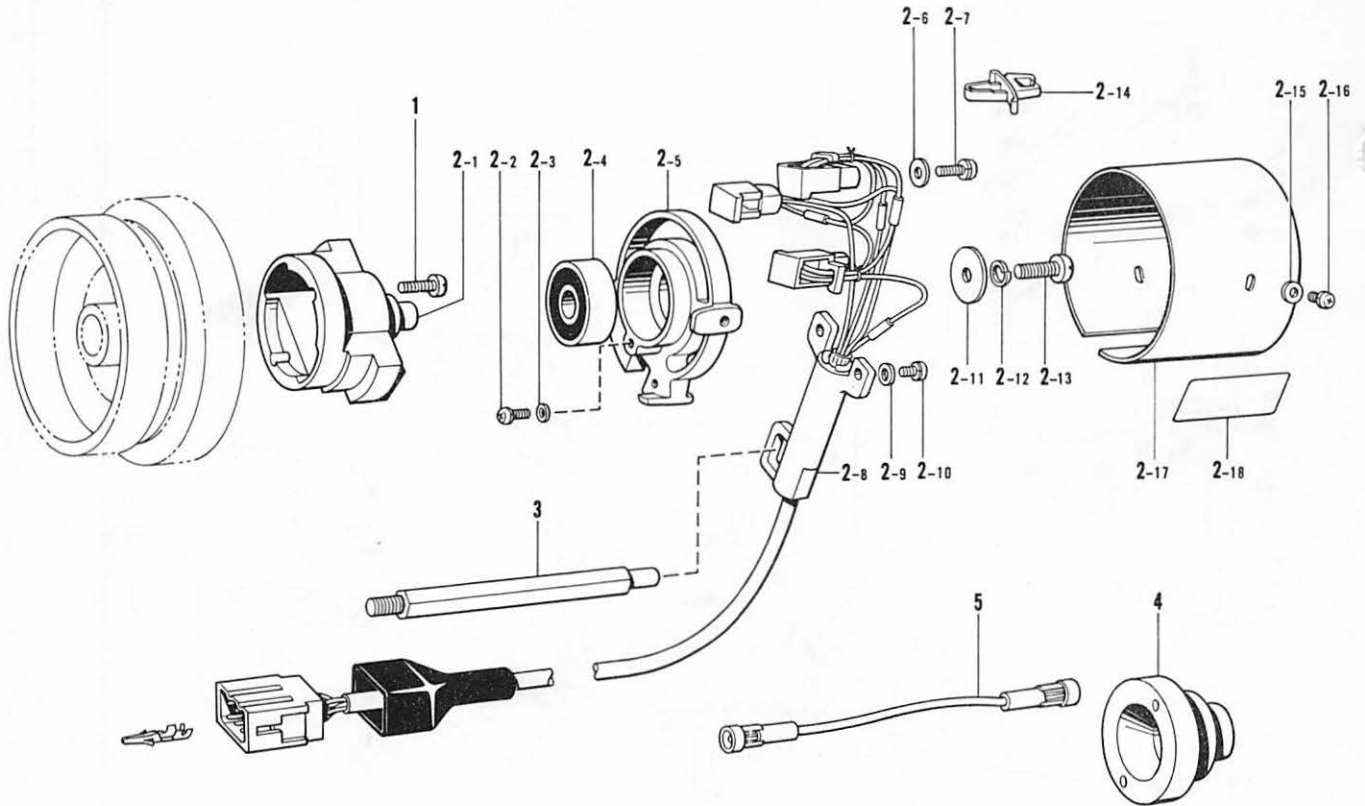

Ref. No.	Name of Parts	Q'ty	Parts No.	Assembly No.	Ref. No.	Name of Parts	Q'ty	Parts No.	Assembly No.
K-1	Screw	2	009711-4-12	Synchronizer Assembly	K-2-11	Washer	1	025060-3-35	Synchronizer Assembly
K-2-1	Magnet Stud	1			K-2-12	Washer	1	028060-2-34	
K-2-2	Screw	1	215083-0-01		K-2-13	Screw	1	216880-0-01	
K-2-3	Washer	1	025030-3-35		K-2-14	Cord Holder	1		
K-2-4	Ball Bearing	1			K-2-15	Washer	2	025040-1-35	
K-2-5	Synchronizer Holder	1			K-2-16	Screw	2	215080-0-01	
K-2-6	Washer	3	025040-3-35		K-2-17	Synchronizer Cover	1		
K-2-7	Screw	3	217093-0-01		K-2-18	Lavel	1		
K-2-8	Hall I, C with Cord	1			K-3	Synchronizer Holder Stud	1	148615-0-01	
K-2-9	Washer	2	025040-1-35		K-4	Slip Ring Support	1		
K-2-10	Screw	2	215080-0-01	K-5	Connecting Cord Assembly	1	147708-0-00		

From the library of: Diamond Needle Corp

N. For 45402 45403 (Heavy) Exclusive Parts

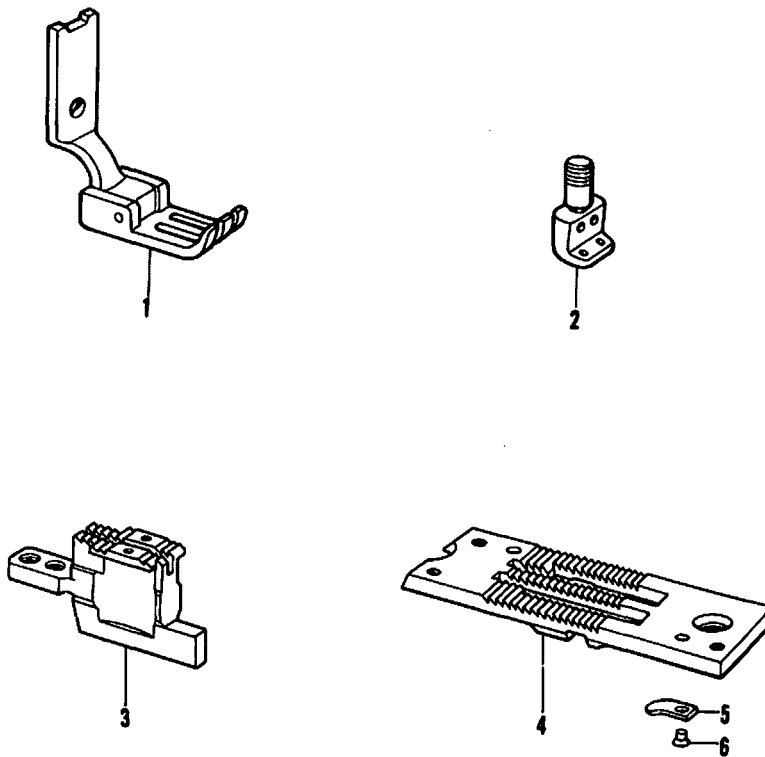

Ref. No.	Name of Parts	Q'ty	Parts No.	Assembly No.
N-1	Presser Foot $\frac{1}{4}$ "	1	148695-0-01	
N-2	Needle Holder Thin $\frac{1}{4}$ "	1	112600-0-01	
N-3	Feed Dog $\frac{1}{4}$ "	1	148705-0-01	
N-4	Needle Plate $\frac{1}{4}$ "	1		Needle Plate Assembly 148724-0-01
N-5	Presser Spring For Fix Knife	2	148708-0-01	
N-6	Pin	2	148709-0-01	

S. For 43402 43403 (Thin, Medium) Exclusive Parts

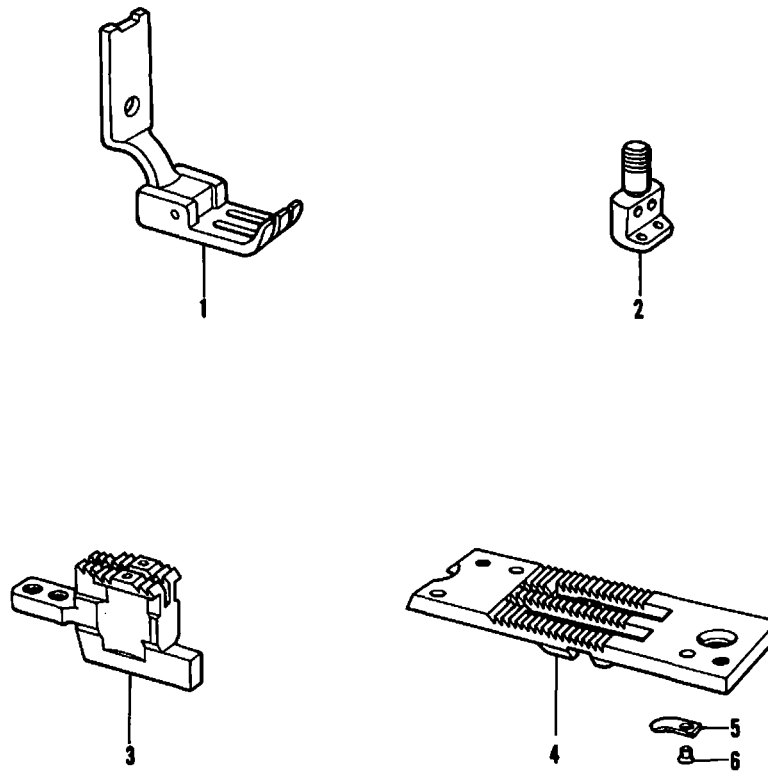

Ref. No.	Name of Parts	Q'ty	Parts No.	Assembly No.
S-1	Presser Foot $\frac{1}{4}$ "	1	148693-0-01	
S-2	Needle Holder Thin $\frac{1}{4}$ "	1	112600-0-01	
S-3	Feed Dog $\frac{1}{4}$ "	1	148704-0-01	
S-4	Needle Plate $\frac{1}{4}$ "	1		Needle Plate Assembly
S-5	Presser Spring For Fix Knife	2	148708-0-01	
S-6	Pin	2	148709-0-01	148722-0-01

Z. Accessories

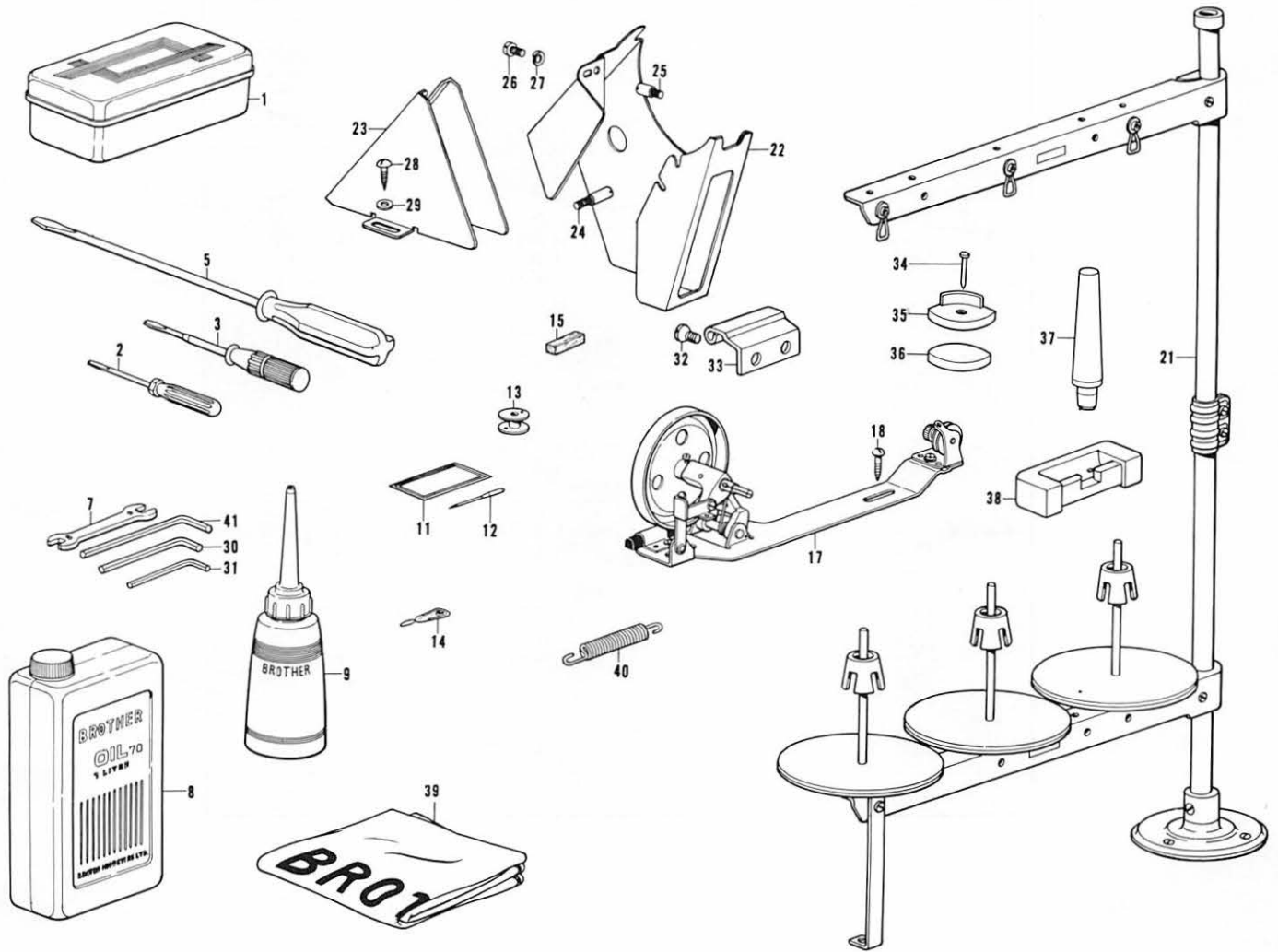

Ref. No.	Name of Parts	Q'ty	Parts No.	Assembly No.	Ref. No.	Name of Parts	Q'ty	Parts No.	Assembly No.
Z-1	Accessory Box	1	110436-0-01		Z-24	Belt Cover Stud C	1	147856-0-02	
Z-2	Screw Driver	1	142443-0-01		Z-25	Belt Cover Stud D	1	147858-0-01	
Z-3	Screw Driver	1	118837-0-01		Z-26	Screw	2	009680-8-12	Belt Cover Complete D 147908-0-01
Z-5	Screw Driver	1	101572-1-01		Z-27	Spring Washer	2	028680-2-42	
Z-7	Spanner 8×9	1	100887-0-01		Z-28	Screw	2	100666-0-02	
Z-8	Oil Tank	1	145277-1-03		Z-29	Washer	2	025750-1-32	
Z-9	Oiler	1	114483-0-01		Z-30	Spanner 3	1	142721-0-01	
Z-11	Needle Bag	1			Z-31	Allen Wrench (2 mm)	1	142002-0-01	
Z-12	Needle DP×5	10			Z-32	Screw	4	112569-0-01	
Z-13	Bobbin	10	148603-0-01		Z-33	Head Hinge	2	148882-0-01	
Z-14	Threader	1	103896-0-02		Z-34	Nail	8	109714-0-00	
Z-17	Bobbin Winder Assembly	1	117963-0-01		Z-35	Head Cushion	4	146003-1-01	
Z-18	Screw	2	100666-0-02		Z-36	Head Cushion Lower	4	148883-0-01	
Z-21	Cotton Stand Assembly	1	150151-0-01		Z-37	Head Rest	1	149010-0-00	
Z-15	Cushion	1	146289-0-01	Belt Cover Complete D 147908-0-01	Z-38	Blower	2	143910-0-01	
Z-22	Belt Cover UD	1			Z-39	Head Cover	1	144222-0-01	
Z-23	Belt Cover D	1			Z-40	Spring	1		
					Z-41	Spanner	1	149570-0-01	

DIFFERENT PARTS LIST

Ref. No.	Specification	43402	43403	45402	45403
A-40	Needle Plate Assembly	148722-0-01		148724-0-01	
A-43,49-65	Upper Tension Control Assembly	181756-0-01		181755-0-01	
A-51	Tension Spring	118317-0-01		148672-0-01	
A-75	Thread Guide Assembly			148656-0-01	
A-76	Screw			108960-0-04	
A-81	Arm Thread Guide, Center	112658-0-01			
A-82	Screw	108960-0-04			
B-36	Needle DP×5	107415-0-14		118536-0-22	
C-16	Presser Foot	148693-0-01		148695-0-01	
D-12	Feed Length Control	143605-0-01		146183-0-01	
D-35	Feed Regulator Shaft Arm	148499-0-01		148500-0-01	
D-55	Feed Dog Medium	148704-0-01		148705-0-01	
E-6,7	Vertical Feed Eccentric Assembly	148804-0-01		181486-0-01	
E-59	Spring	148602-0-01		148601-0-01	
G-3~5	Reverse Solenoid Assembly	148636-0-01	149243-0-01	148636-0-01	149243-0-01
G-19~21	Solenoid Assembly	148648-0-01	149244-0-01	148648-0-01	149244-0-01
G-31	6P Nylon Connector	146118-0-00		146118-0-00	
G-32	Connector Cap	145596-0-01		145596-0-01	
H-3~5	Thread Wiper Solenoid	148509-0-01	149246-0-01	148509-0-01	149246-0-01
H-15	Spring	148526-0-01		148527-0-01	
H-29~31	Switch	146121-0-00	146913-0-00	146121-0-00	146913-0-00
J-6	Thread Presser Plate	148593-0-00		148594-0-00	
J-23	Connector Cap	146119-0-00		146119-0-00	
J-24	Nylon Connector	145681-0-00		145681-0-00	
J-27~30	Thread Trimmer Solenoid	148542-0-01	149245-0-01	148542-0-01	149245-0-01
J-42	Knife Driving Cam	148540-0-01		148541-0-01	
J-59	Spring	148571-0-01		148569-0-01	
K-2-1~2-18	Synchronizer Assembly	218931-0-01		218931-0-01	
K-4	Slip Ring Support		148825-0-01		148825-0-01
Z-12	Needle DP×5	107415-0-14		118536-0-22	
Z-40	Spring	148570-0-01		149175-0-01	
G-5	Terminal Pin Q'ty	2		2	
G-21	Terminal Pin Q'ty	2		2	
H-5	Plunger Pin Q'ty	2		2	
H-31	Terminal Pin Q'ty	2		2	
J-23	Connector Cap Q'ty	1		1	
J-24	Connector Q'ty	1		1	
J-27	Terminal Pin Q'ty	2		2	

From the library of: Diamond Needle Corp

INDEX

Parts No.	Ref. No.	Remark	Parts No.	Ref. No.	Remark	Parts No.	Ref. No.	Remark	Parts No.	Ref. No.	Remark
001630-4-02	J-5		014770-6-22	J-44		107419-0-02	G-33		112694-0-01	E-26	
001670-6-12	F-30		015771-0-12	G-36		107794-0-01	E-37		112695-0-01	E-31	
002040-8-03	J-34		015771-2-12	B-27		"	E-42		112696-0-00	E-23, A-15	
002300-5-05	G-16		018061-6-22	J-13		108254-0-01	A-60		112697-0-01	E-23	
002300-6-03	G-24		021660-1-03	D-58		108263-0-01	A-53		112698-0-01	E-11, 12	
007401-0-13	H-8		021670-1-02	G-60		108265-0-01	A-50		112699-0-01	E-43	
007500-6-02	G-1		021670-1-60	A-49		108266-0-01	A-24		112700-0-01	E-44	
007500-8-02	G-8		021710-2-12	E-30		108549-0-01	D-9		112702-0-01	E-55	
009660-4-12	D-82		021760-3-04	A-14		108960-0-04	A-25		112709-0-01	A-67	
009670-5-12	B-55		025030-2-32	G-17		"	A-27		112712-0-01	A-58	
"	F-18		025030-3-35	K-2-3		"	A-76		112716-0-01	F-26	
"	F-34		025040-1-35	K-2-9		"	A-82		112717-0-01	F-27	
"	F-54		"	K-2-15		109174-0-00	Z-34		112719-0-01	B-48	
009670-6-12	A-74		025040-2-33	H-9		110171-0-01	G-30		112720-0-01	B-50	
009670-6-13	A-68		025040-3-35	K-2-6		110171-0-02	G-57		112721-0-01	B-41	
"	F-11		025060-1-32	D-63		110436-0-01	Z-1		112723-0-01	F-12	
009670-6-14	A-12		025060-3-35	K-2-11		112072-0-01	D-18		112724-0-01	F-8	
009670-8-12	F-24		025630-1-32	J-4		112560-0-01	A-5		112725-0-01	F-7	
"	A-2		025750-1-32	Z-29		112561-0-01	A-8		112728-0-01	B-39	
"	C-13		025770-2-32	E-57		112566-0-01	A-11		112730-0-01	F-5	
"	B-38		028060-2-34	K-2-12		112569-0-01	Z-32		112734-0-01	B-18	
009671-0-12	H-26		028680-2-42	Z-27		112572-0-01	B-20		112735-0-00	B-3	
009679-3-12	H-1		028680-2-43	E-48		112573-0-01	B-17		"	B-64	
"	F-6		031311-3-02	F-16		112574-0-00	B-13		112736-0-00	F-33	
009680-7-13	C-7		047501-2-42	C-33		112576-0-01	B-16		112739-0-01	B-54	
009680-7-14	G-38		048030-3-42	J-15		112577-0-01	B-8		112743-0-01	F-36	
009680-8-12	Z-26		048040-3-42	G-9		112578-0-01	B-4		112745-0-01	F-35	
009681-0-12	D-41		048060-3-42	D-79		112579-0-01	B-1		112751-0-02	A-35	
009681-0-14	A-7		048070-3-42	D-3		112586-0-01	B-24		112753-0-01	F-39	
"	A-66		048080-3-42	H-34		112588-0-01	B-46		112754-0-01	F-38	
009681-4-14	H-32		072620-4-60	B-30		112590-0-01	B-43		112755-0-01	E-52	
009681-6-13	A-6		081016-0-70	F-13		112591-0-01	B-33		112756-0-01	E-50	
009710-8-12	D-34		100022-0-05	J-52		112592-0-01	B-37		112758-0-01	F-22	
"	F-28		100032-0-03	A-41		112593-0-01	B-40		112759-0-01	D-59	
"	J-11		100064-0-02	A-4		112594-0-01	B-47		112760-0-01	B-29	
"	J-26		100078-0-03	J-21		112595-0-00	B-52		112762-0-01	F-1~4	
009711-0-12	J-66					112596-0-01	B-58				
"	F-20		100242-0-03	D-60		112597-0-01	B-57		112764-0-01	B-51	
"	J-32		100248-0-01	B-22		112598-0-01	B-59		112782-0-01	A-3	
"	J-58		100250-0-01	B-15					113014-0-00	B-10	
009711-4-12	G-42		100260-0-01	C-4					113024-0-00	B-7	
"	J-54		100289-0-03	J-49		112600-0-01	N-2		113074-0-01	D-65	
"	J-63		100320-0-02	E-56		"	S-2		113524-0-01	F-25	
"	K-1		100328-0-01	D-15		112606-0-01	A-37		113526-0-01	F-10	
009711-4-13	H-22					112607-0-01	A-36		113050-0-01	C-17	
009761-4-12	D-62		100645-0-03	E-49		112614-0-01	C-5				
009781-4-12	J-18		100666-0-02	Z-18		112615-0-01	C-3		113362-0-01	E-9	
009781-8-12	B-60		"	Z-28		112616-0-01	C-12		113386-0-00	A-42	
"	D-77		100887-0-01	Z-7		112618-0-01	C-10		114297-0-01	F-9	
009782-5-12	G-6		101268-0-03	B-56		112619-0-01	C-11		"	F-17	
011711-4-12	E-32		101572-1-01	Z-5		112623-0-01	C-24		114483-0-01	Z-9	
011802-0-12	J-20		101706-0-01	B-11		112624-0-01	C-22		114486-0-01	F-52	
013680-6-10	D-8		"	D-38		112629-0-01	C-20		114680-0-01	B-21	
013680-6-12	A-28		103896-0-02	Z-14		112626-0-01	C-19		114693-0-01	B-6	
"	G-26		104450-0-01	A-23		112627-0-01	C-25		114909-0-00	C-28	
013689-4-12	C-34					112628-0-01	C-26		115177-0-01	G-51	
013760-8-10	C-15		104908-0-04	C-30		112630-0-01	C-21		115249-0-01	E-3	
"	E-5		"	D-86		112631-0-01	C-9		115287-0-00	E-46	
013761-0-10	B-2		105161-0-02	E-25		112634-0-02	C-29		116010-0-01	A-39	
"	D-4		105234-0-01	E-47		112636-0-01	C-32		116283-0-01	D-54	
"	D-48		105288-0-01	B-63		112656-0-01	D-61		116323-0-01	B-35	
013761-4-10	B-19		105351-0-02	B-53		112658-0-01	A-26		116558-0-01	F-14	
"	B-23					"	A-81		116699-0-00	B-49	
"	B-32		105671-2-12	E-15					117160-0-01	G-62	
"	D-68		106030-0-01	C-36		112666-0-00	E-12		117963-0-01	Z-17	
"	D-84		106640-0-01	F-24		112667-0-01	E-11		118170-0-01	C-23	
013770-7-10	B-12		107030-0-01	B-45		112668-0-01	E-14		118171-0-01	B-5	
"	F-22		107155-0-01	E-40		112684-0-01	E-7		118317-0-01	A-51	
013771-2-12	B-28		107407-0-03	H-10		"	E-21		118320-0-01	A-65	
"	E-19		107231-0-01	A-9		112686-0-01	E-53		118536-0-22	B-16	
013780-7-10	E-13		107278-0-02	D-57		112687-0-01	E-41		"	Z-12	
014760-6-22	G-44		107415-0-14	Z-12		112690-0-01	E-36		118713-0-01	D-32	
014770-6-22	J-68		"	B-16		112692-0-01	E-28		"	G-27	

Parts No.	Ref. No.	Remark	Parts No.	Ref. No.	Remark	Parts No.	Ref. No.	Remark	Parts No.	Ref. No.	Remark
118746-0-01	D-17		148484-0-01	C-27		148594-0-00	J-16				
118747-0-01	D-19		148486-0-01	C-18		148595-0-01	B-33,37,38,40-46		148709-0-01	S-6	
118837-0-01	Z-3		148487-0-01	D-31		148596-0-00	B-42		"	N-6	
118853-0-01	D-36		148488-0-01	D-2		148598-0-01	B-62				
"	D-20		148489-0-01	D-5		148599-0-01	A-38				
118954-0-00	D-45		148490-0-01	D-56		148601-0-01	E-59		148722-0-01	S-4~6	
118865-0-01	G-37		148491-0-01	D-71		148602-0-01	E-59				
123882-0-01	G-49		148492-0-01	D-80		148603-0-01	E-34		148724-0-01	N-4~6	
140021-0-01	E-10		148493-0-01	D-83		"	Z-13				
140527-0-01	A-13		148494-0-01	D-67		148604-0-00	A-29		148726-0-01	D-26	
140620-0-01	J-22		148495-0-01	D-76		148605-0-01	C-37		148727-0-01	E-60	
141494-0-01	J-47		148496-0-00	D-44		148606-0-01	C-39		148728-0-01	E-45	
"	J-61		148499-0-01	D-35		148607-0-01	C-35		148729-0-01	F-19	
141542-0-02	A-71		148500-0-01	D-35		148608-0-01	G-40		148730-0-01	F-32	
141748-0-01	G-34		148501-0-01	D-87		148609-0-01	G-45		148731-0-01	F-31	
142002-0-01	Z-31		148502-0-00	E-8		148610-0-01	A-30		148732-0-01	F-21	
142268-0-01	A-72		148503-0-00	E-2		148611-0-01	A-69		148733-0-01	F-40	
142443-0-01	Z-2		148505-0-01	E-1		148613-0-01	H-36		"	F-48	
142483-0-01	D-11		148507-0-01	A-1		148614-0-01	A-70		148734-0-00	F-41	
142721-0-01	Z-30		148508-0-01	H-24		148615-0-01	K-3		148735-0-01	F-50	
142746-0-01	D-13		148509-0-01	H-3~5		148617-0-01	B-31		148736-0-00	F-51	
142747-0-01	D-14		148511-0-01	H-4		148618-0-01	E-35		148737-0-01	F-42	
143549-0-00	G-5		148513-0-01	H-7		148619-0-01	G-46, 47		148738-0-00	F-43	
"	G-21		148514-0-01	H-2		148623-0-01	G-48		148740-0-00	F-49	
"	J-27		148515-0-01	H-17		148625-0-01	G-52		148741-0-01	F-46	
"	H-5		148516-0-01	H-13		148628-0-01	G-53		148742-0-00	F-47	
143549-0-00	H-31		148517-0-00	H-14		"	G-56		148743-0-01	D-85	
143591-0-01	D-72		148518-0-00	H-11		148629-0-01	G-54		148744-0-01	G-18	
143594-0-01	D-40		148521-0-01	H-16		148630-0-01	G-55		148762-0-01	F-29	
143597-0-01	D-51		148526-0-01	H-15		148631-0-01	G-61		148763-0-01	G-25	
143598-0-01	D-10		148527-0-01	H-15		148632-0-01	G-58		148764-0-01	G-11	
143605-0-01	D-12		148529-0-01	H-21		148633-0-01	G-65		148765-0-01	G-15	
143610-0-01	D-33		148530-0-01	H-20		148634-0-01	G-63		148767-0-01	G-28	
143613-0-01	D-46		148531-0-01	J-10		148635-0-01	G-64		148768-0-01	G-59	
143616-0-01	D-78		148535-0-01	J-7		148636-0-01	G-3~5		148770-0-01	H-23	
143657-0-01	F-23		148536-0-01	J-8		148637-0-01	G-4		148771-0-01	D-39~43	
143673-0-01	D-81		148537-0-01	J-9		148638-0-01	G-43		148801-0-01	D-44~46	
143710-0-01	J-17		148538-0-01	J-1		148640-0-01	G-41		148802-0-01	D-47, 48	
143766-0-01	D-1		148539-0-01	J-3		148641-0-01	G-29		148803-0-01	E-16, 17	
143910-0-01	Z-38		148540-0-01	J-42		148642-0-01	G-13		148804-0-01	E-6, 7	
143972-0-01	F-15		148541-0-01	J-42		148643-0-01	G-7		148818-0-01	A-73	
144222-0-01	E-39		148542-0-01	J-27~30		148648-0-01	G-19~21		148819-0-01	E-60	
144680-0-01	A-63		148545-0-01	J-30		148650-0-01	G-20		148821-0-01	E-18	
144681-0-01	A-62		148546-0-01	H-18		148651-0-01	G-22		148825-0-01	K-4	
144682-0-01	A-61		"	J-31		148652-0-01	G-12		148835-0-01	C-6, 7	
144683-0-01	A-64		148547-0-01	J-36		148653-0-01	G-14		148882-0-01	Z-33	
145277-1-03	Z-8		148548-0-01	J-35		148654-0-01	G-50		148883-0-01	Z-36	
145328-0-01	D-42, 43		148553-0-01	J-45		148655-0-01	J-25				
145502-0-01	D-16		148554-0-01	J-48		148656-0-01	A-75		149010-0-01	Z-37	
145596-0-01	G-32		148555-0-01	J-37					149169-0-01	J-2	
145681-0-00	J-24		148557-0-01	J-40		148662-0-01	A-77		149174-0-01	G-10	
146080-0-00	H-6		148559-0-00	J-38		148663-0-01	A-78		149177-0-01	H-19	
"	H-27		148560-0-01	G-2		148664-0-01	A-79		149179-0-01	A-83	
146118-0-00	G-31		148561-0-01	J-33		148665-0-01	A-80		149243-0-01	G-3~5	
146119-0-00	J-23		148562-0-01	J-16		148666-0-01	A-48		149244-0-01	G-19~21	
146120-0-01	H-25		148567-0-01	J-14		148667-0-01	A-47		149245-0-01	J-27~30	
146121-0-00	H-29~31		148568-0-01	J-19		148668-0-01	A-46		149246-0-01	H-3~5	
146125-0-01	H-33		148569-0-01	J-59		148669-0-01	A-52		150151-0-01	Z-21	
146128-0-00	H-37		148571-0-01	J-59		148670-0-01	A-55		180157-0-01	B-25, 26	
146141-0-01	B-14		148573-0-01	J-56		148671-0-01	A-54		180321-0-01	D-37, 38	
146183-0-01	D-12		148574-0-01	J-43		148672-0-01	A-51		180949-0-01	E-20, 38	
146289-0-01	Z-15		148575-0-01	J-55		148674-0-01	C-35		181712-0-01	J-41	
146913-0-01	H-29~31		148577-0-01	J-64		148693-0-01	S-1		181713-0-01	J-39	
147708-0-00	K-5		148579-0-01	J-57					181755-0-01	A-43, 49~65	
147856-0-02	Z-24		148580-0-01	J-65		148695-0-01	N-1		181756-0-01	A-43, 49~65	
147858-0-01	Z-25		148584-0-01	J-60					215080-0-01	K-2-10	
147908-0-01	Z-15, 22~29		148585-0-01	J-60, 62		148704-0-01	S-3		"	K-2-16	
148005-0-01	E-27		148586-0-01	J-62					215083-0-01	K-2-2	
148394-0-00	B-9		148587-0-01	J-46		148705-0-01	N-3		216880-0-01	K-2-13	
148480-0-01	E-54		148589-0-01	J-51					217093-0-01	K-2-7	
148481-0-01	E-51		148591-0-01	J-50		148708-0-01	N-5		218931-0-01	K-2-1, 2-18	
148482-0-01	J-12		148592-0-01	J-53		"	S-5		403616-0-01	H-28	
148483-0-01	C-8		148593-0-00	J-16					503093-0-01	F-53	



118-832-400
195832-0-22
April 1977
Printed in Japan